

Mobius® ADC Reactor

Scalable family of single-use mixing systems, perfected for bioconjugation of Antibody Drug Conjugates

The Mobius® ADC Reactor is a single-use mixing systems family, specifically designed for the key conjugation step to manufacture Antibody Drug Conjugates (ADCs). Offering scalability from 4 L to 500 L, this dedicated solution brings all the benefits from using single-use to the conjugation step. These include achieving faster turnaround times, avoiding cross-contamination risks, cleaning procedures and validation, while maintaining high product quality with no compromise on process continuity and operator safety.

Leveraging the features of proven Mobius® MIX and Power MIX single-use mixer families, the Mobius® ADC Reactor has been perfected to meet the specific challenges associated with the conjugation step. Its single-use assemblies are made of Ultimus® Film technology, providing enhanced bag strength, improved durability, and leak resistance to ensure operator safety. Incorporating woven nylon into the new film has increased its durability while maintaining the ease of handling, flexibility, and conformity that ADC processes demand.

Designed with the requirements of conjugation in mind

- Addition ports enable tailored material handling and precision, minimizing splashing and foaming during critical component addition.
- Uncompromised safety for a step involving use of highly potent pharmaceutical ingredients, with a bag made of robust components and film.

From late development phase to manufacturing

- Linear scalability to accommodate varying batch sizes across three sizes (10 L, 100 L, 500 L), from development scale to large-scale manufacturing.
- Conjugation reaction consistency scaling up or down and similar user-experience and training requirements.



All the benefits of single-use applied to conjugation

- Uncompromised quality with a selection of single-use product-contact components with proven compatibility and resistance to solvents such as DMAc and DMSO, ensuring product quality.
- Uncompromised safety of supply chain thanks to damage-resistant Ultimus® Film, with superior strength and leak resistance, ensuring improved bag integrity.
- Compared to stainless steel or glass reactors, single-use decreases implementation time and cost in production due to elimination of cross-contamination concerns and cleaning programs. Contribution to toxic waste streams during the cleaning process is also reduced.

System components

Reagent addition dip tubes:
No splashing, no foam reagent addition via plunging dip tubes.



Wide swing door:
Accessibility to install and remove single-use assembly conveniently.



Jacketed carrier:
For temperature control during conjugation.

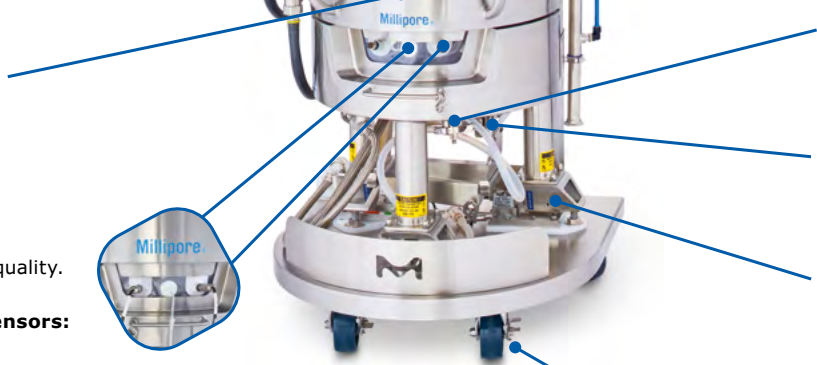

Sampling:
Needle-free sampling for uncompromised sample quality.



pH and conductivity sensors:
Monitoring in process.

Support Bracket:
Safely holds dip tube ports and vent filter to avoid dangling lines.

Protein/mAb addition port:
Side addition port for controlled, no foam introduction to preserve product quality.

Levitronix® Mixing Technology:
For gentle liquid-liquid mixing.

Temperature sensor:
No-product-contact sensor to monitor temperature during conjugation.

Load cells:
Weight monitoring in process. Locking mechanism when carrier is moved.

Large easy-roll wheels:
Convenient movement and repositioning of the carrier, with brakes to lock in position during use.

Note: The temperature sensor setup differs for the 10 L scale. Refer to the specification table for more details.

Mobius® ADC Reactor Performance

Tailored design for conjugation reaction efficiency

ADC-specific features of the single-use assemblies

The Mobius® ADC Reactor is tailored for the precise requirements of bioconjugation. Distinct ports on the single-use assembly are designed for the addition of solvents and monoclonal antibodies (mAb) with a focus on minimizing splashing and foaming during the mAb addition process, thus helping to preserve product quality. The quality of mixing and solvent addition supports reaction efficiency comparable to conjugation performed in glass or stainless steel vessels. The single-use solution reduces cleaning requirements and change-over time, with no compromise made for a safe working environment and operator protection. Leveraging Ultimus® film for the assemblies brings increased leak resistance, preventing risk of operator exposure to toxic compounds during conjugation.

Mixing efficiency

The mixing performance of the Mobius® ADC Reactor is comparable to glass or stainless steel vessels, which are typically used for conjugation. In a study conducted using a model solution, mixing efficiency and temperature control were characterized to assist users in the integration of using this single-use technology in their manufacturing workflow.

Uncompromised product quality and operator safety

Since compatibility with typical conjugation solvents is a requirement for that step, all single-use components have been tested for compatibility with dimethylsulfoxide (DMSO) and dimethylacetamide (DMAc). More information can be found on our website.

Single-Use Assembly Certification Level

Given the criticality of the conjugation step and risks associated to highly potent pharmaceutical ingredients, the highest level of certification has been selected, where every single assembly has been tested for leaks in manufacturing. Certification of an assembly is based on the qualification of the components in the assembly, the level of leak testing performed during manufacturing, and the testing performed on the assembly lot after manufacturing. The certification level also impacts the shelf life and sterility claims that are made for the assembly. Details of the Mobius® ADC Reactor single-use assembly certification level are summarized in the table below.

Gold	Shelf life	Sterility	USP <85> Endotoxins, USP <788> Sub-visible particulates	Leak testing	Component material meet the criteria for Biological Reactivity Testing. These tests can be any or a combination of the following test methods: USP<88> Class VI (in vivo), USP<87> (in vitro), ISO 10993-5 (in vitro).
	2 years	Sterile (Quarterly dose audit)	One assembly per lot tested	100% assembly leak tested	Post-gamma irradiation

Automation and Process Analytics

Ready to Connect Control Box

The Mobius® ADC Reactor can be monitored and controlled locally or remotely. Plug the ready to connect control box to the network and use Ethernet IP communication protocol to monitor speed, weight, temperature, pH and conductivity remotely. The ready to connect control box is a separate box on a four wheels chassis that can be easily moved around the Mobius® ADC Reactor carrier. The 21 CFR Part 11 compliant data recorder option displays data trends in real time and ensures process data integrity when recording.



100 L Mobius® ADC Reactor with Ready to Connect Control Box.

Related products

Mobius® Single-Use Chromatography Systems

The Mobius® Chromatography systems are flexible, automated, single-use chromatography systems that enable consistent and reliable separation and purification at pre-clinical and manufacturing scale. Their single-use flowpath offer the flexibility to operate in functionally or fully closed mode, reducing contamination and exposure risk. The systems deliver operational flexibility for processes from 50 to 2000 L with flow rates from 0.1 to 20 L/min, a 5:1 turn down ratio at process scale and enhanced isocratic and linear gradient accuracy.



Eshmuno® CMX Chromatography Resin

Eshmuno® CMX chromatography resin is a mixed mode chromatography resin built on the proven Eshmuno® resin technology. This resin combines weak cation exchange properties with hydrophobic interaction, providing high selectivity for ADCs purification.



Mobius® Single-Use TFF Systems

Our Mobius® FlexReady Solution for TFF and Mobius® TFF 80 system provide a combination of single-use Flexware® assemblies and hardware specifically designed for efficient concentration and diafiltration of proteins. With installable filter area ranging from 0.5 to 20 m², flow range from 2 to 80 L/min, and tank size from 50 to 500 L, our range of single-use TFF systems can adapt to ADC purification process needs from pre-clinical to manufacturing scale. Closed mode of operation is possible to protect operators while increasing flexibility and efficiency.



Pellicon® Capsule Manifolds

Our innovative TFF capsules are ideal for processing biopharmaceuticals that require single-use capabilities, including enhanced ease-of-use, process flexibility, rapid product turnaround, and reduced operator exposure. First-of-its-kind, the capsule has a holderless and self-contained design for fast and flexible product changeover.



Pellicon® 2 and Pellicon® 3 Cassettes

These advanced, high-performance cassettes are ideal for high titer therapeutic antibodies, as well as more demanding filtration processes that require higher operating pressures, temperatures, and caustic cleaning regimes.



Mobius® ADC Reactor Services

The pharmaceutical and biotechnology industries are highly regulated and, to help you navigate this challenging environment, we offer a wide range of services. These services help you save time, lower costs, and comply with regulations. For your peace of mind, all our services are performed by our global experts who have an intimate knowledge of our equipment backed by decades of experience.

Qualification Services

Our qualification services are designed to make the integration of our system into your process as seamless as possible and ensure your equipment is properly installed and functioning per your pre-defined requirements.

- Factory acceptance test (FAT)
- Installation qualification/operational qualification (IQ/OQ)
- Performance qualification support (PQ)

Note: Release tests are included with the system by default.

For additional information on qualification tests, please contact your local sales representative to get the detailed Test Matrix document.

Training Services

Appropriate training for users is not only a cGMP requirement, it also ensures your staff has the expertise to operate and manage the system as part of your manufacturing process. Our training offering has been designed to make your staff more autonomous in managing your system and your process while saving time and money. Our training services cover system use and programming with interactive hands-on sessions and, depending on the training you select, may also include:

- Installing the Mobius® ADC Reactor assemblies
- Troubleshooting issues
- Process recommendations

These trainings can be delivered either at your site or in our M Lab™ Collaboration Centers.

Please contact your local representative or email ilearn@milliporesigma.com to discuss our training offering.

System Service Reliance Plans

To help you ensure optimum equipment uptime while mitigating risks, we have developed a wide range of services and support that allow you to select a coverage level that best fits your needs. Our System Service Reliance Plans, a complete range of services for your systems, offer priority access to support while ensuring your equipment is properly maintained. For additional details, please refer to the System Service Reliance Plans Data Sheet (MK_DS7881EN) available at www.SigmaAldrich.com/services-plans

Repair Services and Spare Parts

Repair Services

In the event your system experiences a problem, our worldwide engineering organization will provide on-site or repair center technical support to get you back up and running as quickly as possible.

Spare Parts

Purchasing spare parts directly from us is the only way we can guarantee that you get the right parts every time, with the same level of performance as the original.

Mobius® ADC Reactor is supported by the Emprove® Program – The Smart Way to Master Compliance and Control

Complementing our product portfolio, the Emprove® Program provides convenient access to reliable technical, regulatory and supply information in Emprove® Dossiers to support your risk assessment continuum. A subscription to our Emprove® Suite can help you stay current: In addition to accessing the Emprove® Dossiers, you can also receive notification updates to document changes, as well as generate download metrics and reports.

For more information, please visit:

www.SigmaAldrich.com/emprove-FandSU

Specifications

Carrier				
Description	10 L	100 L	500 L	
Materials of Construction	Tank	Stainless steel 304 minimum		
	Stand	Stainless steel 304 minimum		
	Latch	No latch	Protex, stainless steel	
	Casters	Stainless steel 304 minimum with polyurethane wheel	Stainless steel 304 minimum with polyurethane wheel	Stainless steel 304 minimum with polyurethane wheel
Dimensions L × W	813 × 813 mm (32 × 32 in.)	813 × 813 mm (32 × 32 in.)	1188 × 1188 mm (47 × 47 in.)	
Height	1058 mm (42 in.)	1395 mm (55 in.)	1641 mm (65 in.)	
Weight	177 kg (390 lb)	257 kg (566 lb)	505 kg (1110 lb)	
Maximum Volume (L)	10	100	500	
Minimum Sampling Volume (L)	3.5	25	92	
Minimum Working Volume (L)	1	10	50	
Fluid volume in jacket (approx.)	1.46 L (0.39 gal)	3.84 L (1.01 gal)	11.04 L (2.91 gal)	
Heat transfer area of jacket (approx.)	0.53 sq m (5.77 sq. ft)	1.40 sq m (15.15 sq. ft)	4.04 sq m (43.55 sq. ft)	
Maximum operating pressure of jacket	6.2 bar (90 psig)	6.2 bar (90 psig)	6.2 bar (90 psig)	
Safety/Jacket Vent valve pressure rating	6.9 bar (100 psi)	6.9 bar (100 psi)	6.9 bar (100 psi)	
Stainless Steel Jacketed Carriers ASME U-1 code stamped	Optional			
Load Cells (Quantity 3) Ingress Protection Rating	110 kg (0–250 lb) ±1% FS IP 68	220 kg (0–500 lb) ±1% FS IP 68	550 kg (0–1250 lb) ±1% FS IP 68	
Non-Product Contact RTD Temperature Sensor	N/A	0–60 °C ± 1°C	0–60 °C ± 1°C	
Product-contact RTD Temperature Sensor (316L Stainless Steel)	0–60 °C ± 1 °C	N/A	N/A	
pH Sensor	0–14 pH ±0.1 pH			
Conductivity Sensor	0.2–200 mS/cm ±10% FS			
Storage temperature	0–40 °C (non-condensing environment)			
Operating temperature	4–60 °C (non-condensing environment)			
Mixing Operating Viscosity	0–40 cP			
Motor Speed*	0–1000 rpm	0–500 rpm	0–250 rpm	
Operating and Storage Relative Humidity Range	15–95% (non condensing)			
Regulatory Compliance	The system bears the CE marking			
Pressure Safety	Jacketed stainless steel units are assessed to be under Sound Engineering Practices			

*Impeller must be covered by liquid.

Motor				
Description	10 L	100 L	500 L	
Weight	1.4 kg (3.1 lb)	4.9 kg (10.8 lb)	13.1 kg (29 lb)	
Electrical (max)	50 W	300 W	1200 W	
Design speed (max)*	1000 rpm	500 rpm	250 rpm	
Cable Length	2.7 m (9 ft)	3 m (10 ft)	3 m (10 ft)	
Ingress Protection rating	IP 67	IP 67	IP 67	
Regulatory Information	CE marked			

*Maximum operating speed has to be validated for each process individually, depending on volume, viscosity, etc.

Ready to Connect Control Box			
Description	10 L	100 L	500 L
Materials of Construction	Stainless steel 304 minimum		
Dimensions L × W	741 × 566 mm (29 × 22 in.)		
Height	1249 mm (49 in.)		
Weight without Data Recorder	119 kg (263 lb)	119 kg (264 lb)	122 kg (268 lb)
Weight with Data Recorder	123 kg (270 lb)	123 kg (271 lb)	125 kg (275 lb)
Electrical	100–230 VAC, 50/60 Hz, 7.7/4.4 A single phase	100–230 VAC, 50/60 Hz, 7.2/4.1 A single phase	200–208 VAC, 3 ph, 50/60 Hz, 8.3 A (North America) 220–230 VAC, 50 Hz, 9.8 A single phase
Cable Length	4.9 m (16 ft)		
Ingress protection rating	IP 55		
Regulatory Information	CE, CB Scheme, NRTL		
Data Recorder Eurotherm	Optional		

Single-Use Assembly Materials of Construction	
Description	Material
Bag	Ultimus® Film
mAb Addition Port	Polyethylene
Impeller Cup	HDPE
Impeller	Sintered neodymium magnet NdFeB encased in polypropylene
TC Port	Polyethylene
TC Cap	Polypropylene
TC clamp	Nylon
Port Plate	Polyolefin
EJ Female Luer Barbed Fitting	Polypropylene
Gasket	Platinum Cured Silicone
Dip Tubes	Non-Print PharMed Tubing
Pharma 50 Tubing	Platinum Cured Silicone
Pharma 65 Tubing	Platinum Cured Silicone
Pharma 80 Tubing	Platinum Cured Silicone
Needle-free sample port	HDPE
O-ring	Silicone
Conductivity and pH sensor (multi-use)	EPDM and 316L stainless steel
Vent Filter: Opticap® XL 300 Capsule Filter with Millipore Express® SPG Hydrophobic membrane	Polypropylene Hydrophobic Polyethersulfone, Polybutylene terephthalate based blend

Ordering information

To tailor the Mobius® ADC Reactor to your needs, select:

Hardware

- A carrier size (10, 100, or 500 L)
- A motor for your corresponding carrier
- A control box for your corresponding carrier (according to your region)
- A control box power cord

Note: All control boxes are supplied with multi-use pH and conductivity sensors. The 10 L is supplied with a multi-use temperature sensor.

Consumables

- The single-use bag assembly for the corresponding carrier
- The matching dip-tubes set, for solvent addition

Mobius® ADC Reactor Hardware

		10 L	100 L	500 L
Carrier	Stainless steel jacketed with temperature sensor and load cells	ADCMXRJ10TL	ADCMXRJ100TL	ADCMXRJ500TL
	Stainless steel jacketed, ASME certified, with temperature sensor and load cells	ADCMXRJ10TLA	ADCMXRJ100TLA	ADCMXRJ500TLA
Ready to Connect Control Box	Unit with 115/230 V power supply	ADCCBC1V1S	ADCCBC2V1S	
	Unit with 115/230 V power supply + data recorder	ADCCBC1V1SR	ADCCBC2V1SR	
	Unit with 208 V 3P power supply			ADCCBC3V2S
	Unit with 208 V 3P power supply + data recorder			ADCCBC3V2SR
	Unit with 230 V power supply			ADCCBC3V3S
	Unit with 230 V power supply + data recorder			ADCCBC3V3SR
Motor		SN5SPKEL1MIXER	MIX0200L107	MIX0500L107

Power Cords

Description	Catalog Number
North America, NEMA 5-15P, IEC Plug Type B	SMPCNA
Europe, CEE 7/7, IEC Plug Type F	SMPCEU
Australia, New Zealand, AS/NZS 3112, IEC Plug Type I	SMPCANZ
India, IS1293, IEC Plug Type M	SMPCIN
Switzerland, SEV-1011 Type 12, IEC Plug Type J	SMPCSZ
United Kingdom, BS 1363/A, IEC Plug Type G	SMPCUK
Japan, JIS 8303, IEC Plug Type B	SMPCJP
China, GB2099, IEC Plug Type I	SMPCCH
Single Phase Flying Leads (without plug)	SMPC1FL
200/208 VAC 3 Phase Flying Leads (JP/NA) (without plug)	SMPC3FL

Mobius® ADC Reactor Single-Use Assemblies

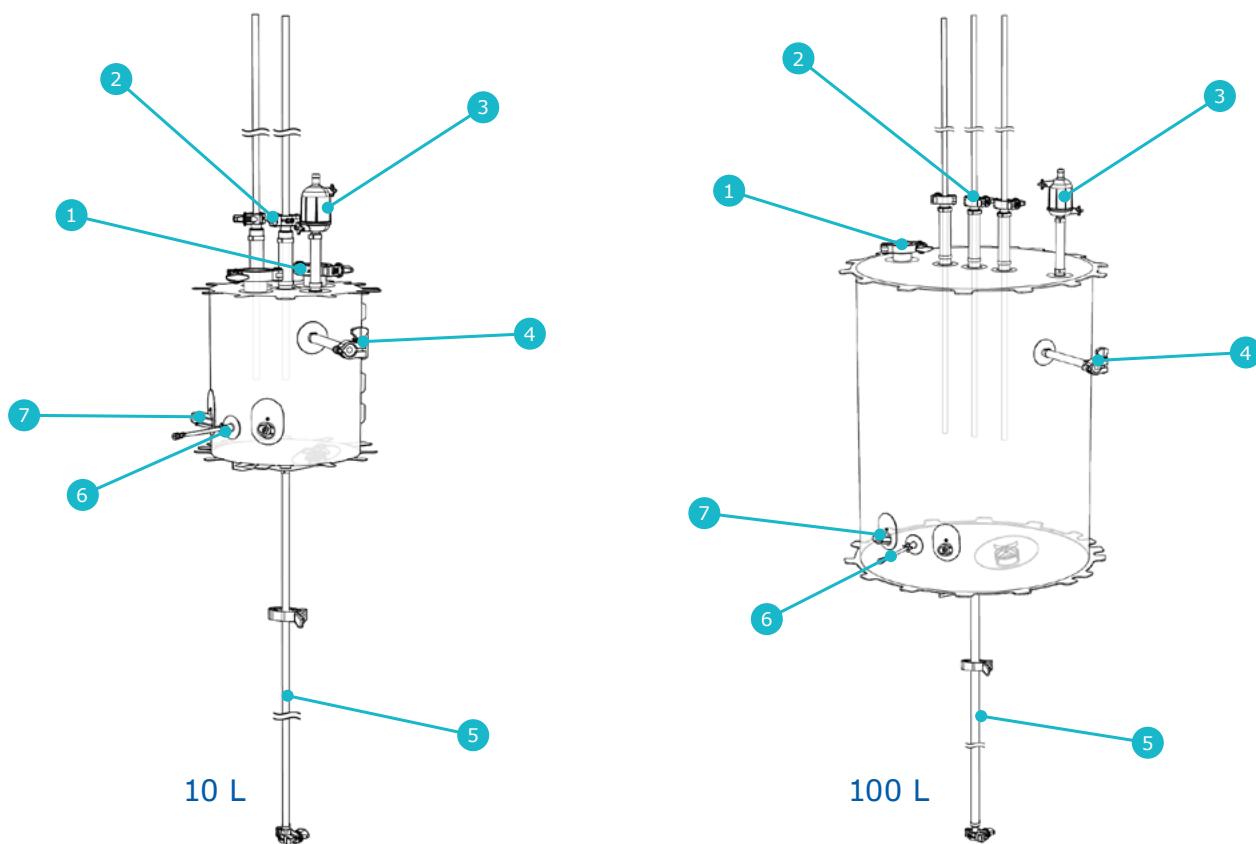

Bag assembly specifications

Volume	Catalogue number	Quantity per pack	Top Ports	Bottom Port	mAb addition port	Side ports
10 L	ADCMXR0010LG3L	3	<ol style="list-style-type: none"> 1 2x 1.5" TC, gasket and cap 2 2x 3/4" ID Silicone tubing – 5" + 3/4" TC, gasket and cap 3 1/2" ID Silicone tubing – 5" + Opticap® XL300 SPG 0.2 Vent Filter 	<ol style="list-style-type: none"> 5 1/4" ID + 3/4" TC, gasket and cap 	<ol style="list-style-type: none"> 4 3/8" ID Silicone tubing – 6" + 3/4" TC, gasket and cap 	<ol style="list-style-type: none"> 6 Needle Free Sample Port + 3 mm ID Silicone tubing – 4" + pinch clamp. 1/8" HB Luer 7 2x Probe Port for Multi-Use Sensor + cap
100 L	ADCMXR0100LG2L	2	<ol style="list-style-type: none"> 1 1.5" TC, gasket and cap 2 3x 3/4" ID Silicone tubing – 5" + 3/4" TC, gasket and cap 3 1/2" ID Silicone tubing – 5" + Opticap® XL300 SPG 0.2 Vent Filter 	<ol style="list-style-type: none"> 5 1/2" ID + 1" 1/2" TC, gasket and cap 	<ol style="list-style-type: none"> 4 3/8" ID Silicone tubing – 6" + 3/4" TC, gasket and cap 	<ol style="list-style-type: none"> 6 Needle Free Sample Port + 3 mm ID Silicone tubing – 4" + pinch clamp. 1/8" HB Luer 7 2x Probe Port for Multi-Use Sensor + cap
500 L	ADCMXR0500LG1L	1	<ol style="list-style-type: none"> 1 1.5" TC, gasket and cap 2 3x 3/4" ID Silicone tubing – 5" + 3/4" TC, gasket and cap 3 1/2" ID Silicone tubing – 5" + Opticap® XL300 SPG 0.2 Vent Filter 	<ol style="list-style-type: none"> 5 1/2" ID + 1" 1/2" TC, gasket and cap 	<ol style="list-style-type: none"> 4 3/8" ID Silicone tubing – 6" + 3/4" TC, gasket and cap 	<ol style="list-style-type: none"> 6 Needle Free Sample Port + 3 mm ID Silicone tubing – 4" + pinch clamp. 1/8" HB Luer 7 2x Probe Port for Multi-Use Sensor + cap

Dip tube selection table

Corresponding bag volume	Catalogue number	Quantity per pack	Flow Rate Range	Tubing ID
10 L	ADCDT010G31	3 × 2 dip tubes	1.7 – 1000 mL/min	¼" Non-Print Pharmed Tubing 12.5 ft + Silicone gasket and cap
	ADCDT010G32	3 × 2 dip tubes	0.8 – 480 mL/min	⅛" Non-Print Pharmed Tubing 12.5 ft + Silicone gasket and cap
	ADCDT010G33	3 × 2 dip tubes	1.7 – 1000 mL/min, 0.8 – 480 mL/min	¼" Non-Print Pharmed Tubing 12.5 ft + Silicone gasket and cap and 1 × ⅛" Non-Print Pharmed Tubing 12.5 ft + Silicone gasket and cap
100 L	ADCDT100G21	2 × 3 dip tubes	1.7 – 1000 mL/min	¼" Non-Print Pharmed Tubing 12.5 ft + Silicone gasket and cap
500 L	ADCDT500G11	1 × 3 dip tubes	4.8 – 2900 mL/min	⅜" Non-Print Pharmed Tubing 12.5 ft + Silicone gasket and cap

Mobius® ADC Reactor Services

Product Description	Catalog Number
Qualification Services	
Mobius® ADC Reactor – Factory Acceptance Test execution including protocol in English	SSVFATADC
Mobius® ADC Reactor – IQOQ execution including protocol in English and travel	SSVQUADC
System Service Reliance Plans	
Mobius® ADC Reactor – Essential Service Plan execution including protocol in English and travel	SSVESPADC
Mobius® ADC Reactor – Advanced Service Plan execution including protocol in English and travel	SSVESPADC + SSVADCADC
Mobius® ADC Reactor – Total Service Plan execution including protocol in English and travel	SSVESPADC + SSVTOCADC
Mobius® ADC Reactor – System Preventive Maintenance (additional to service plan)	SSVPRMADC

For additional information, please visit www.SigmaAldrich.com/ADC-reactor

To place an order or receive technical assistance, please visit www.SigmaAldrich.com/offices

We provide information and advice to our customers on application technologies and regulatory matters to the best of our knowledge and ability, but without obligation or liability. Existing laws and regulations are to be observed in all cases by our customers. This also applies in respect to any rights of third parties. Our information and advice do not relieve our customers of their own responsibility for checking the suitability of our products for the envisaged purpose

